

# 2G Motion System



**AKM2G servo motor and AKD2G drives**  
A flexible, single-source solution with unrivaled  
power density and control



**KOLLMORGEN**

A REGAL REXNORD BRAND

# Intentional design. Streamlined setup. Ultimate performance.

The Kollmorgen 2G Motion System delivers a servo motor and drive system designed to work together for ultimate compatibility, ease of setup and higher performance; and the flexibility, power and control to bring any design to life with individual components as needed.

## Power in a compact package

Experience unmatched performance and torque density with the Kollmorgen 2G Motion System. AKM2G servo motors deliver an average of 30% greater torque density than previous generations all without increasing the package size or altering mounting requirements. This allows OEMs to reduce the footprint of their machines without sacrificing performance. Complementing this, the AKD2G drive streamlines your design with a single-cable connection, dual-axis drives, and advanced smart features, reducing the bill of materials and enhancing overall efficiency.

## Ease and flexibility

The Kollmorgen 2G Motion System components are designed to work together for seamless, plug-and-play operation—reducing commissioning time, improving performance and giving designers greater flexibility and control. The AKM2G motor and AKD2G drive can be used together as a system, or independently for ultimate personalization.

## Industry-leading support

When you choose a Kollmorgen system, you'll benefit from industry-leading firmware, motor sizing and selection guidance, dependable supply, application expertise, and personalized support that no other motion provider can offer.

## AKD2G servo drive

Powerful, personalized, plug-and-play

From its single-cable connection to industry-leading power density, the AKD2G servo drive delivers ultimate flexibility and high performance.

- Industry-leading power density in a compact, easy-to-mount package—available in both one- and two-axis variants
- Single-cable SFD & HIPERFACE® DSL connection simplifies commissioning and reduces the bill of materials, with the flexibility to choose from a wide range of other feedback devices
- EtherCAT® & FSoE, CANopen®, Ethernet/IP with CIP Sync, and PROFINET IRT compatibility for flexible communication options
- STO SIL2/PLd implemented as standard; optional SafeMotion™ Monitor (SMM), SIL3/PLe to meet functional safety needs and enable a wider range of applications

## AKM2G servo motor

Efficient performance in a compact package

Achieve your desired performance in less space with the AKM2G Series servo motor—optimized for use with the AKD2G family of high-performance servo drives.

- High torque density for substantial machine performance increases without increasing the size of the motor
- High power in a small package to reduce the footprint of new machine designs
- Achieve greater flexibility with multiple shaft, mounting and connector choices; six motor sizes and five stack lengths; multiple feedback device options; and an optional holding brake.
- Plug-and-play compatibility with AKD2G drives for easier setup



## Available AKD2G models

The AKD2G drive, with expanded options, allows for greater flexibility, ease of setup and performance than ever before. From extended I/O variants and additional feedback options to built-in functional safety, choose the configuration to meet your needs.

### Base Model

The base AKD2G speeds up commissioning with a single-cable SFD & HIPERFACE® DSL connection—or choose from a wide range of other feedback devices. This model features STO SIL2/PL.

### Extended I/O Variant

The extended I/O variant offers everything on the base model, plus I/O expansion. This I/O expansion includes the 15-pin D-sub for legacy feedback devices or dual-loop operation; it also includes an additional 12 I/O for a total of 28 I/O.

### SafeMotion Monitor (SMM) Option

Meet functional safety needs and enable a wider range of applications with optional SafeMotion™ Monitor (SMM), SIL3/PLe.

### Enhanced feedback option enables

- Dual-loop Feedback
- Legacy Feedbacks
- Resolver
- A-QUAD-B
- EnDAT
- BiSS
- sin/cos, etc.
- EEO (encoder emulation)



## AKD2G Servo Drive Extensive Safety Functions for SafeMotion™

Our drive-resident SafeMotion™ safety functions are designed for simple implementation. They provide a full range of SafeStop, SafeSpeed and SafePosition options to suit virtually any requirement.

### STO (Safe Torque Off)

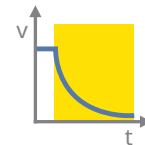

STO safely interrupts the power supply to the motor in the servo drive. The motor becomes torque-free.

### SS1 (Safe Stop 1)

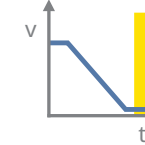

The drive is brought to a standstill by controlled braking. Then the power supply to the motor is safely interrupted and the motor becomes torque-free.

### SBC/SBT (Safe Brake Control & Safe Brake Test)

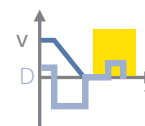

Test function for external brakes and the internal motor holding brake, far simpler than testing brake from PLC/PAC.

### SOS² (Safe Operating Stop)

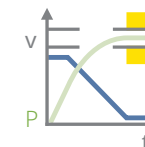

Monitors the stop position reached and triggers SS1 in the event of deviations beyond the specified limits. The control functions of the drive remain active.

### SDI¹ (Safe Direction)

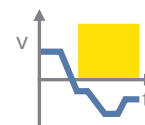

The SDI function ensures that the drive can only move in a defined direction. In the event of an error, SS1 is triggered.

### SSR¹ (Safe Speed Range)

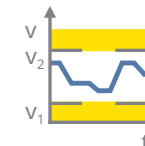

Monitors that the drive observes a defined speed range. In the event of an error, SS1 is triggered.

### SLS¹ (Safe Limited Speed)

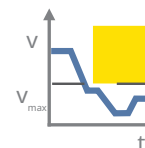

Monitors that the drive observes a defined speed limit. In the event of an error, SS1 is triggered.

### SS2¹ (Safe Stop 2)

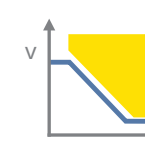

The drive is brought to a standstill by controlled braking and subsequently remains in controlled standstill. The control functions of the drive are maintained.

### SLP¹ (Safe Limited Position)

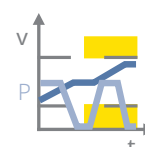

Monitors the absolute position of the drive. If the limit value is reached or the brake torque is too low to keep the drive within the limit value, SS1 is triggered.

### SLI¹ (Safe Limited Increments)

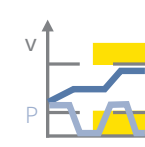

Monitors the relative position of the drive with respect to the current position when activating the SLI function. SS1 is triggered when the prescribed limit value is reached.

## Industry-Leading Smart Drive Features

- Boost performance and eliminate the need for an external controller with Action Tables (built-in drive intelligence)
- Get started quickly with auto-tuning; plus make efficient manual adjustments with wizard-based tuning and advanced Bode plot tools
- Enable unique or specialized applications with drive customization options
- Minimize maintenance downtime and commissioning with easy-to-read drive status on a color graphical display.

## AKD2G Servo Drive Models

120/240 Vac

Model	Continuous Current	Peak Current	Typical Shaft Power	Internal Regen		Height	Width	Depth	Depth w/ cable bend radius
	(Arms)	(Arms)	(kW)	(W)	(Ω)	mm (in)	mm (in)	mm (in)	mm (in)
AKD2G-SPx-6V03S	3	9	1	100	15	235 (9.25)	76 (2.99)	221 (8.70)	232 (9.13)
AKD2G-SPx-6V06S	6	18	2						
AKD2G-SPx-6V12S	12	30	4						
AKD2G-SPx-6V03D	3 & 3	9 & 9	1 & 1						
AKD2G-SPx-6V06D	6 & 6	18 & 18	2 & 2						

240/480 Vac

Model	Continuous Current	Peak Current	Typical Shaft Power	Internal Regen		Height	Width	Depth	Depth w/ cable bend radius
	(Arms)	(Arms)	(kW)	(W)	(Ω)	mm (in)	mm (in)	mm (in)	mm (in)
AKD2G-SPx-7V03S	3	9	2	100	33	270 (10.6)	75 (2.95)	221 (8.70)	232 (9.13)
AKD2G-SPx-7V06S	6	18	4						
AKD2G-SPx-7V12S	12	30	8						
AKD2G-SPx-7V24S	24	72	16	140	15	335 (13.19)	100 (3.94)	274 (10.79)	291 (11.46)
AKD2G-SPx-7V03D	3 & 3	9 & 9	2 & 2	100	33	272 (10.71)	75 (2.95)	221 (8.70)	232 (9.13)
AKD2G-SPx-7V06D	6 & 6	18 & 18	4 & 4						

## AKD2G Drive Connector Layout

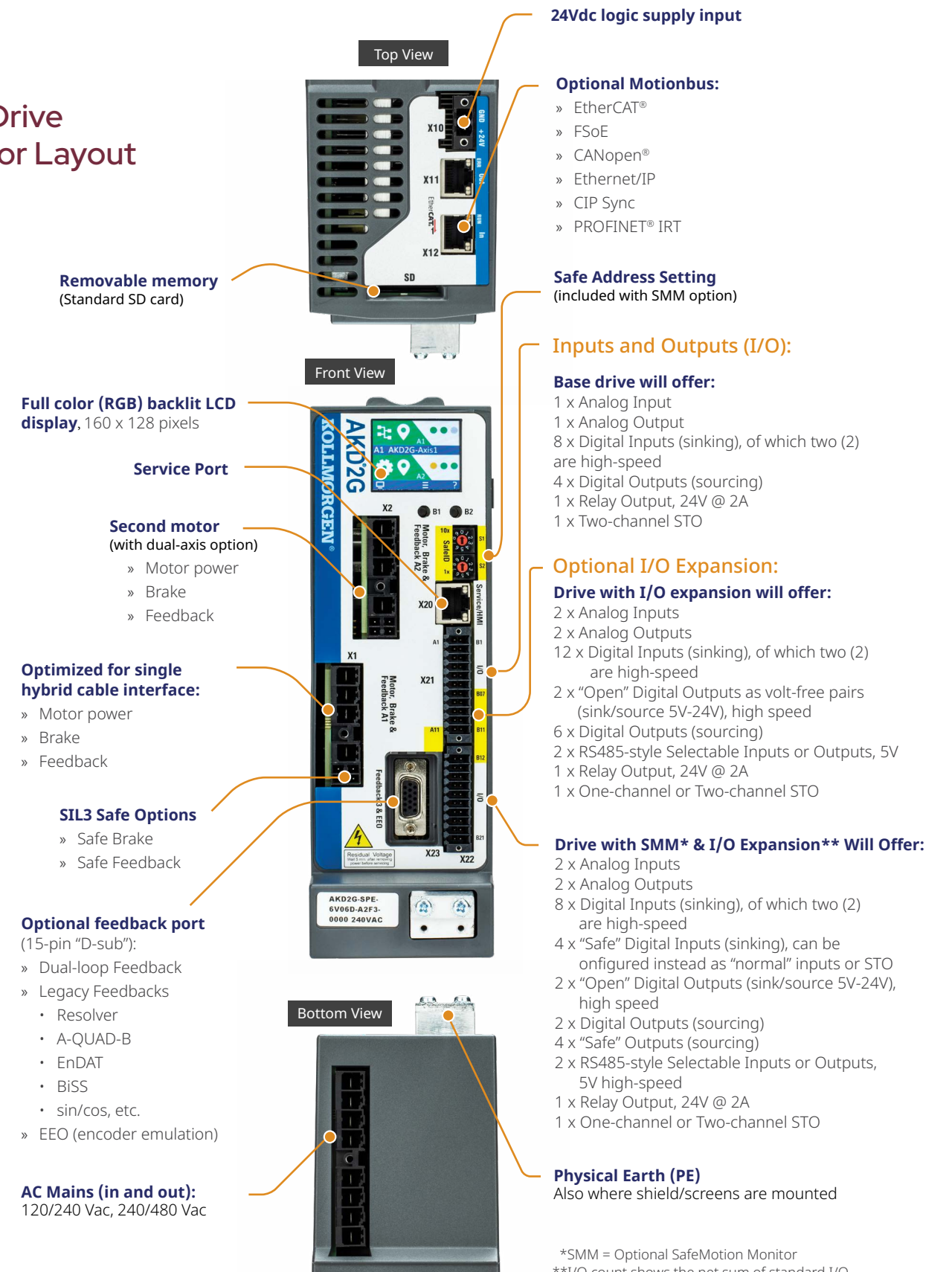

## AKM2G offers industry-leading torque density and torque-to-inertia ratios for next-gen machine design

With significant torque capability, OEMs and users can achieve substantial performance gains for next-generation machine designs.

Higher torque density translates to smaller machine footprints, while industry-leading torque-to-inertia ratios enable higher acceleration and improved throughput without sacrificing precision.

### Cable Options:

- » Single Cable SFD3 / SFD-M / HIPERFACE DSL / EnDat 2.2\*
- » Dual Cable Resolver
- » Single and Dual Cable Co-Engineered options for additional feedback models

### Connector Options:

- » Speedtec
- » ytec

Significant continuous torque increases without increased size

### Low Friction Shaft Seal Options

- » For High Protection Class
- » Choice of Viton® or Teflon® seals

### Feedback Options:

- » SFD3
- » HIPERFACE DSL Functional Safety
- » EnDat 2.2 Functional Safety
- » Resolver
- » Co-Engineered options for additional feedback models

Holding Brake Option

### Thermal Sensor Options:

- » Pt-1000 + Avalanche PTC
- » Pt-1000
- » Avalanche PTC
- » KTY84-130

## Achieve your desired performance in less space

For new machine designs, the AKM2G allows customers to decrease the size, footprint, and complexity of the machine, while still getting the power and performance they need.

The AKM2G drops right into existing machine designs to increase performance, when compared to competing motors, without increasing the size of the motor.

The AKM2G features six sizes with performance levels between 0.18 and 12 kW. It offers selectable options such as feedbacks, mounting configurations, and performance capabilities. Due to the modular structure of the products, Kollmorgen is well equipped to adapt motors to the requirements of a specific application in parallel with standard production needs. This enables machine builders to select from a wider range of standard models that leverage Kollmorgen's extensive product and application knowledge.

The space required for traditional motors

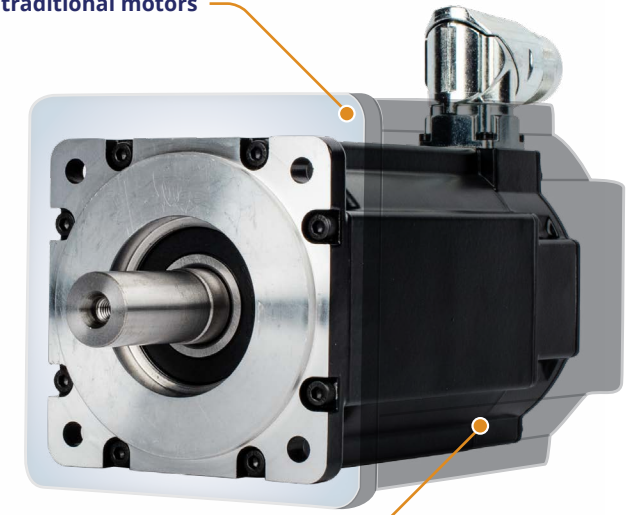

The space required for the AKM2G



AKM2G motors are optimized for use with the AKD2G family of servo drives, unlocking their full optimized performance. They are also compatible with other Kollmorgen drives or your preferred servo drives, though without the enhanced benefits offered by AKD2G drives.

AKM2G Series Servo Motor Family



Performance Data\*

		Frame															
		AKM2G-2x					AKM2G-3x					AKM2G-4x					
Parameters	Sym	Units	1	2	3	4	5	1	2	3	4	5	1	2	3	4	5
Continuous Torque at Stall	T <sub>c</sub>	Nm	0.65	1.12	1.51	1.85	-	1.70	2.90	3.86	-	-	2.87	5.12	6.98	8.51	-
		lb-in	5.76	9.92	13.4	16.3	-	15.1	25.7	34.1	-	-	25.4	45.3	61.8	75.3	-
Rated Speed	N <sub>rd</sub>	rpm	8000	8000	8000	8000	-	8000	7600	8000	-	-	6000	6000	6000	5400	-
Rotor Inertia	J <sub>m</sub>	kg-cm <sup>2</sup>	0.0930	0.1549	0.2169	0.2789	-	0.4264	0.8130	1.200	-	-	0.774	1.36	1.95	2.53	-
		lb-in-s <sup>2</sup>	8.23E-05	1.37E-04	1.92E-04	2.47E-04	-	3.77E-04	7.20E-04	1.06E-03	-	-	6.85E-04	1.20E-03	1.72E-03	2.24E-03	-

		AKM2G-5x					AKM2G-6x					AKM2G-7x					
Parameters	Sym	Units	1	2	3	4	5	1	2	3	4	5	1	2	3	4	5
Continuous Torque at Stall	T <sub>c</sub>	Nm	6.83	12.0	16.2	20.1	-	15.3	21.5	27.0	32.7	23.0	41.1	57.8	72.1	-	
		lb-in	60.4	106	144	178	-	135	190	239	289	204	364	512	638	-	
Rated Speed	N <sub>rd</sub>	rpm	6000	5600	5100	4800	-	5000	4500	4200	3800	4900	3400	3200	3000	-	
Rotor Inertia	J <sub>m</sub>	kg-cm <sup>2</sup>	4.58	0.1549	6.64	8.70	-	9.10	13.0	16.9	20.8	25.9	46.8	67.7	88.6	-	
		lb-in-s <sup>2</sup>	2.23E-03	2.23E-03	5.88E-03	7.70E-03	-	8.05E-03	1.15E-02	1.49E-02	1.84E-02	2.29E-02	4.14E-02	5.99E-02	7.84E-02	-	

Kollmorgen continues to offer other AKM® servo motors with performance levels between 0.075 and 19.5 kW, as well as food-grade, wash-down, and the innovative AKMH™ Hygienic Stainless Steel motors for wash-down and food grade applications where machine builders and customers require the highest performance and most durable product in the harshest of environments. AKM motors can also be used on the AKD2G servo drives and benefit from many of its advanced capabilities.



AKM2G Nomenclature **AKM2G - 3 1 A - A N C N CA 0 0**

Available Motor		Available Options	
Motor Series	AKM2G	Motor Series	AKM2G
1 Motor Series	AKM2G	6 Shaft	C = Closed Keyway N = Smooth
2 Flange	2 3 4 5 6 7	7 Connector	A = AKM first-generation connectors, backwards compatible with AKM cables, not compatible with AKM2G cables C = Dual right angle M23 D = Single right angle M23 E = single right angle M40 H = Dual right angle M40 J = Single right angle M40 Y = y-tec® connector
3 Rotor Stack Length	1 = 1 stack 2 = 2 stacks 3 = 3 stacks 4 = 4 stacks 5 = 5 stacks	8 Brake	N = No Brake 2 = 24 V dc brake
4 Motor Winding	A, B, C...	9 Feedback Device	2- = 2048 LPR commutating encoder AA = BiSS-B single-turn absolute AB = BiSS-B multi-turn absolute DA = EnDat 2.1 single-turn absolute DB = EnDat 2.1 multi-turn absolute CA = Smart feedback device (SFD3) CB = Multi-turn smart feedback device (SFD-M) GU = Safe multi-turn hiperface DSL LD = Safe multi-turn inductive EnDat 2.2 R = Resolver
5 Mount	A = Metric IEC G = Alternate international standard	10 Thermal Sensor	0 = PT-1000 + Avalanche PTC 1 = PT-1000 2 = Avalanche PTC 3 = KTY84-130 (or equivalent)
		11 Shaft Seal/Customization	0 = No seal V = Viton spring lip seal (wet enviro.) T = Mineral filled PTFE (dry enviro.)

\*Not all configurations are compatible. Please refer to the selection guide for specific feedback type and connector compatibility.

Dimensional Overview

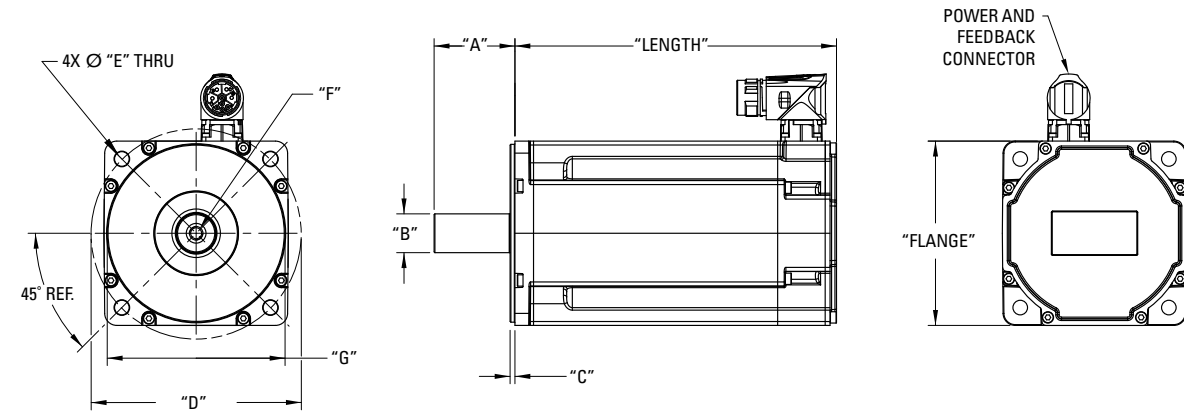

AKM2G Series	Flange IEC	Length Stacks					A	Ø B	C	Ø D	Ø E	F	Ø G
		1	2	3	4	5							
AKM2G2x	58 [2.28]	111 [4.38]	130 [5.13]	149 [5.89]	168 [6.65]	-	23.0 [0.91]	11.0 [0.433]	2.50 [0.98]	63.0 [2.48]	5.5 [0.217]	M4 DIN 332	40.0 [1.57]
w/ Brake		150 [5.91]	169 [6.67]	189 [7.43]	208 [8.19]	-							
AKM2G3x	72 [283]	121 [4.78]	153 [6.01]	184 [7.23]	-	-	30.0 [1.18]	14.0 [0.551]	2.50 [0.98]	75.0 [12.95]	5.5 [0.217]	M5 DIN 332	60.0 [2.36]
w/ Brake		163 [6.40]	194 [7.63]	225 [8.85]	-	-							
AKM2G4x	88 [3.46]	125 [4.91]	151 [5.94]	177 [6.97]	203 [8.01]	-	40.0 [1.57]	19.0 [0.748]	3.00 [0.118]	100.0 [3.94]	6.6 [0.259]	M6 DIN 332	80.0 [3.15]
w/ Brake		172 [6.79]	199 [7.82]	225 [8.85]	251 [9.89]	-							
AKM2G5x	114 [4.49]	143 [5.62]	172 [6.78]	202 [7.94]	231 [9.09]	-	50.0 [1.97]	24.0 [0.945]	3.00 [0.118]	130.0 [5.12]	9.0 [0.354]	M8 DIN 332	110.0 [4.33]
w/ Brake		200 [7.87]	229 [9.02]	259 [10.18]	288 [11.34]	-							
AKM2G6x	142 [5.59]	-	168 [6.62]	190 [7.49]	212 [8.35]	234 [9.22]	58.0 [2.28]	32.0 [1.26]	3.50 [0.138]	165.0 [6.50]	10.19 [0.401]	M12 DIN 332	130.0 [5.12]
w/ Brake		-	234 [9.21]	256 [10.07]	278 [10.94]	300 [11.81]							
AKM2G7x	192 [7.56]	169 [6.66]	203 [7.99]	237 [9.33]	271 [10.67]	-	80.0 [3.15]	38.0 [1.50]	4.00 [0.157]	215.0 [8.47]	13.4 [0.527]	M12 DIN 332	180.0 [7.087]
w/ Brake		247 [9.71]	281 [11.05]	315 [12.38]	349 [13.72]	-							

Dimensions in mm [inches]. Nominal dimensions shown for resolver and Smart Feedback SFD3 motors of less than 20 amps continuous. See individual motor schematics for tolerances and complete dimensions, including other feedbacks and motors rated greater than 20 amps continuous.





## About Kollmorgen

Kollmorgen has more than 100 years of motion experience, proven in the industry's highest-performing, most reliable motors, drives, AGV control solutions and automation platforms. We deliver breakthrough solutions that are unmatched in performance, reliability and ease of use, giving machine builders an irrefutable marketplace advantage.

[www.kollmorgen.com](http://www.kollmorgen.com)

**KOLLMORGEN**

A REGAL REYNOLD BRAND